

MILLWRIGHT: _____

APPRENTICE: _____

Service On Site
7804-100 Ave.
Fort St. John B.C.
V1J 1V7
Tel: (250) 787-0082
Fax: (250) 787-0051
E mail: serviceonsite@shaw.ca



DIMENSIONAL DATA

1. PUMP

2. DRIVER

3. PROCESS

Date:

Customer:

Location:

Equipment Number:

Pump Name:

Manufacturer:

Model:

Size:

S/N:

Driver Manufacturer

Driver Style:

Driver HP/RPM/Voltage/PH:

Frame:

Fluid/Concentration:

Specific Gravity:

Tempurature:

Vapor Pressure:

Suction Pressure:

Discharge Pressure:

Seal Chamber Pressure:

Shaft Speed:

Flush Pan/orifice:

Shaft DIA. (A):

Sleeve DIA. (B):

Sleeve Extension: (C):

Stuffing Box Bore (D):

Stuffing Box Depth (E):

Dist. to 1st obstruction (F):

Number of Bolts/studs (G):

Bolt Size & Bolt Circle (H/I):

Max. Gland O.D. (N):

Secondary Bore (J):

Secondary Depth (K):

Sleeve Balance DIA. (L):

Depth to Step in Sleeve (M):

Secondary Depth (N):

Length of Stud (O):

X/Y Dimensions for
Unequally Space Bolts ?:

MECHANICAL SEAL DESCRIPTION:

MATERIALS:

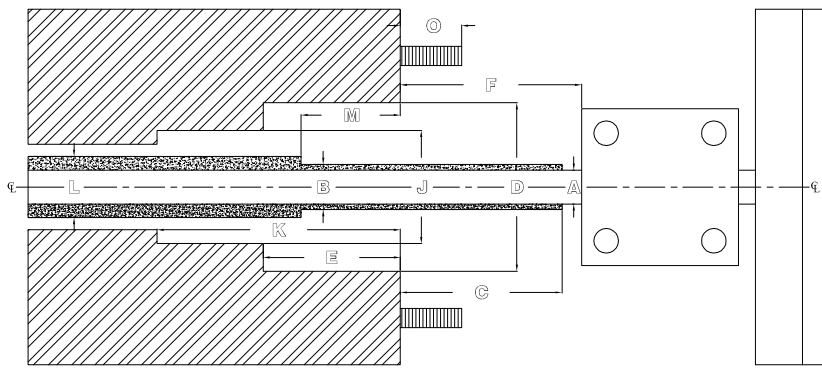

CROSS SECTIONAL VIEW

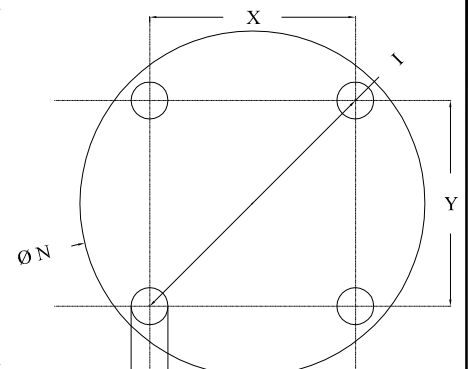

PLAN VIEW

REMARKS AND RECOMONDATIONS:

Blank lines for entering remarks and recommendations.